

ENGINE COMPONENTS (Outer parts)

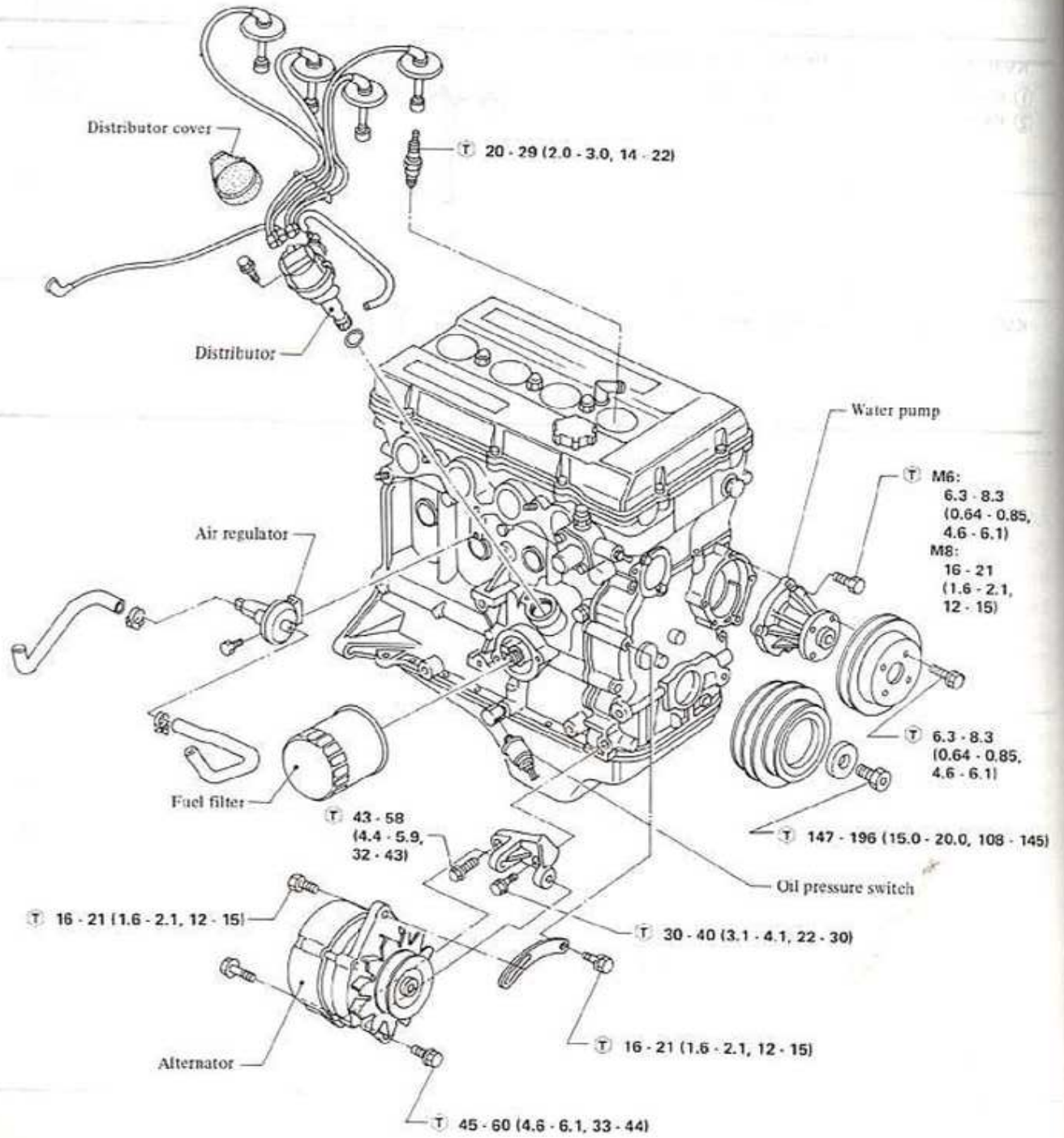

T : N·m (kg·m, ft·lb)

CYLINDER HEAD

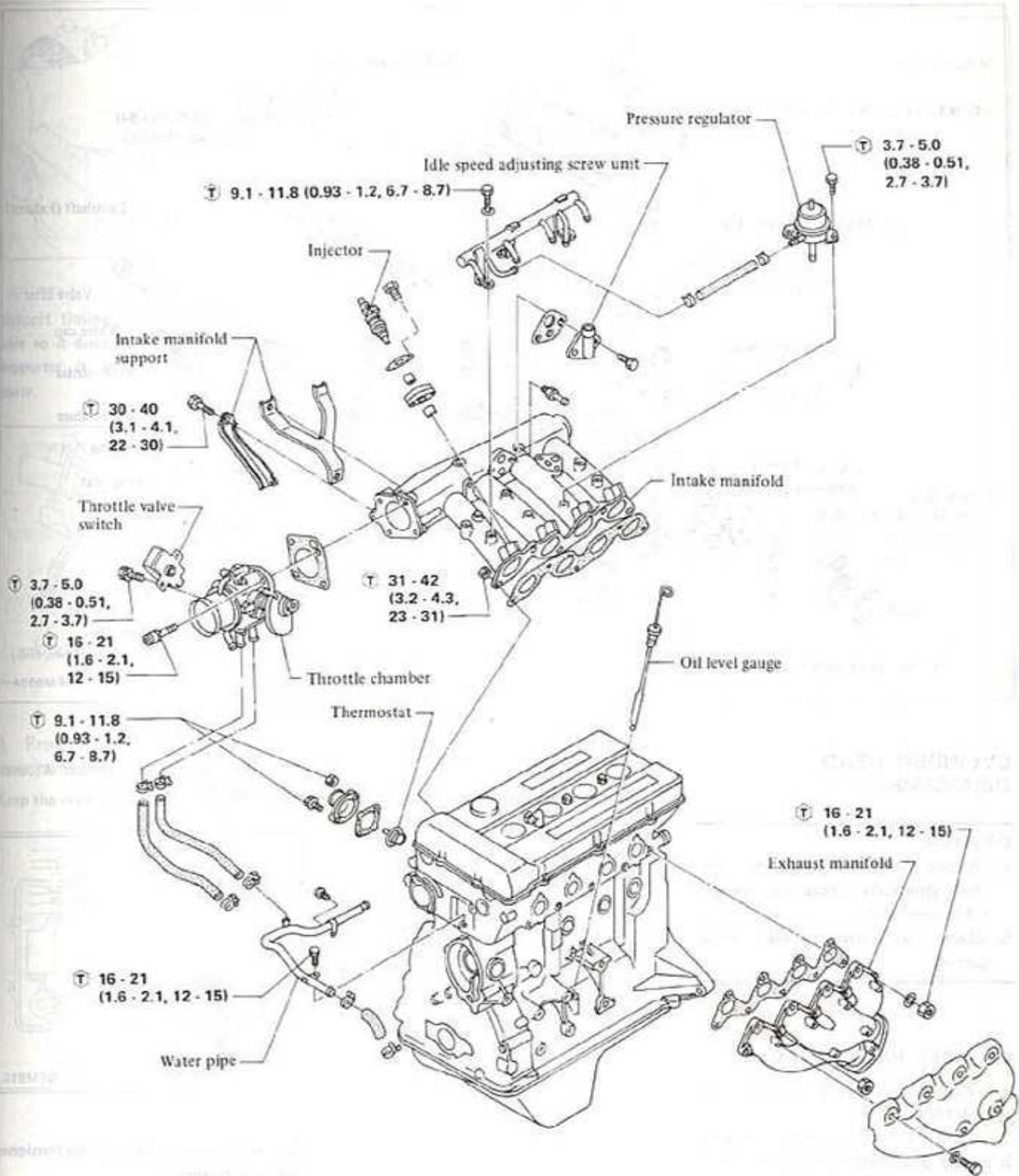

Ⓣ : N·m (kg·m, ft·lb)

CYLINDER HEAD

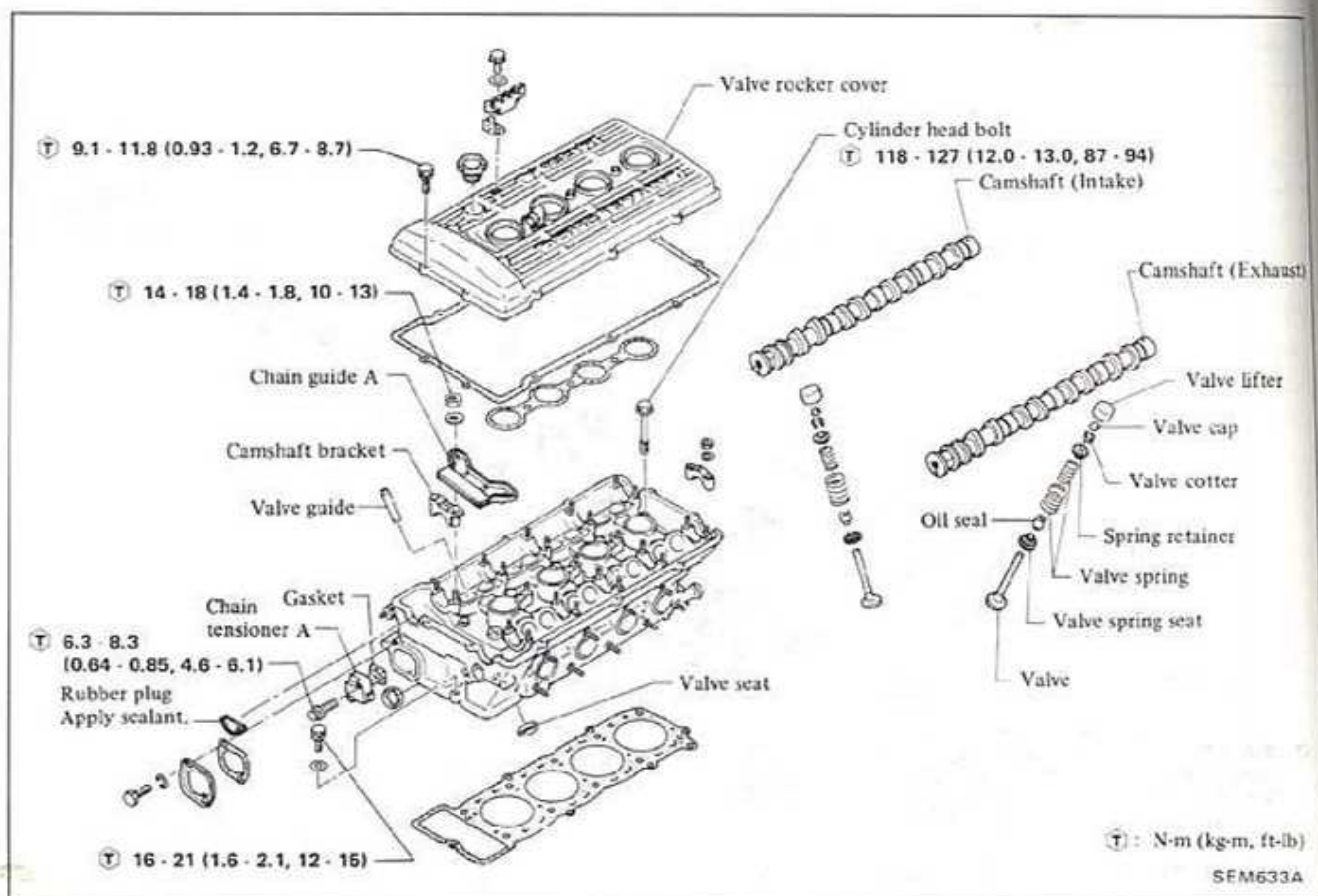
CYLINDER HEAD
DISASSEMBLY

CAUTION:

- Do not rotate crankshaft and camshaft separately, because valves will hit piston heads.
- Always use new cylinder head gasket.

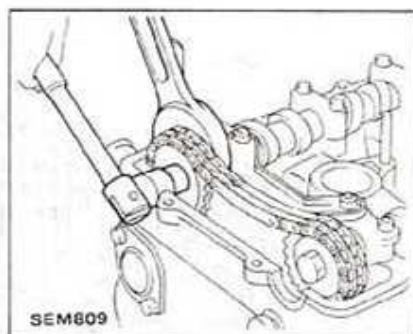

- Remove chain tensioner A cover and chain tensioner A.

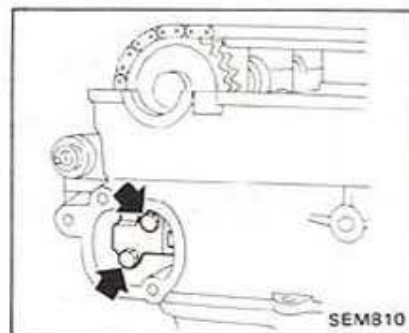

CYLINDER HEAD REMOVAL

- Remove outer parts attached to cylinder head.
- Turn crankshaft until No. 1 piston is at top dead center on its compression stroke.
- Scribe marks on timing chain and camshaft sprockets with paint before removal.
- Loosen camshaft sprocket bolts.

Be careful not to drop chain tensioner sleeve and spring.

6. Remove camshaft sprockets.

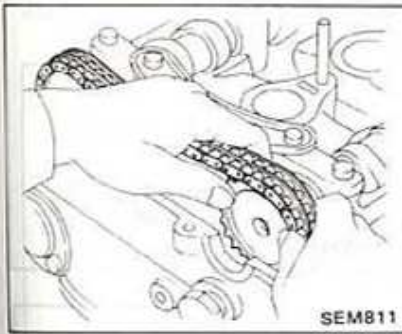

Support timing chain with a proper wire so it does not fall, however the supporter is located on the front cover.

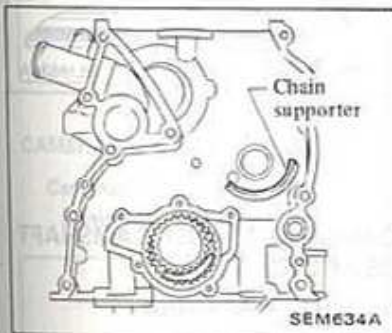

7. Remove camshaft brackets and chain guide A in the sequence below.

Keep the removed brackets in order.

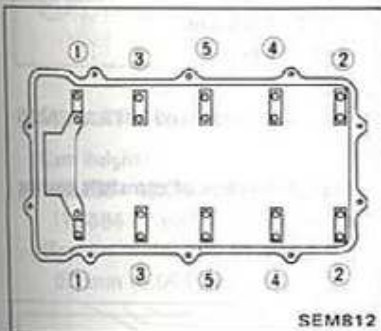

8. Remove camshafts.

9. Remove chain guide C upper bolt.

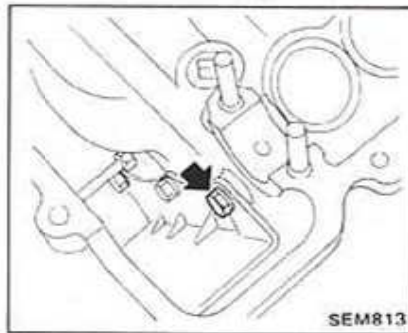

10. Loosen cylinder head bolts in two or three stages.

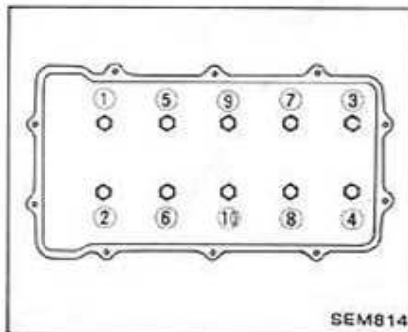

11. Remove cylinder head.

12. Disassemble cylinder head.

Keep the disassembled parts in order.

(1) Remove valve lifters and caps.

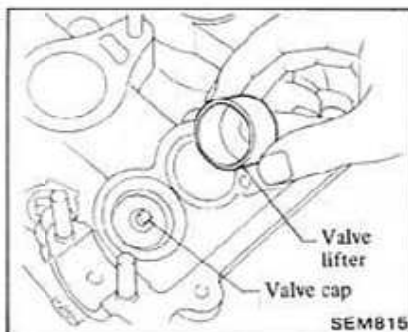

Valve lifter can be removed easier by using magnet or suction rubber.

(2) Remove valves and springs using Tool.

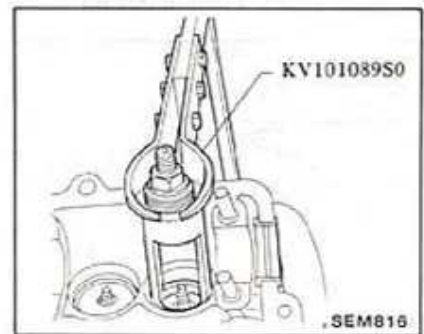

Pay particular attention not to damage valve lifter guide hole.

(3) Remove valve oil seals using Tool.

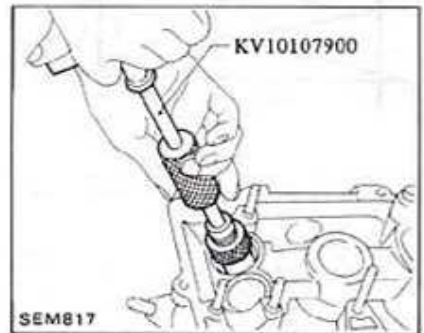

(4) Remove valve spring seats.

CYLINDER HEAD DISTORTION

Warpage of surface:
Less than 0.1 mm (0.004 in)

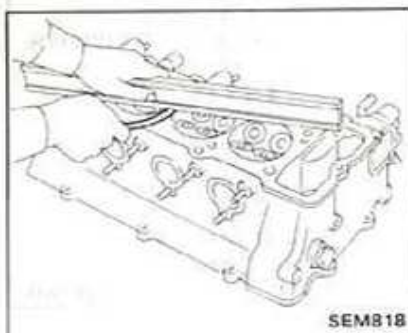

SEM818

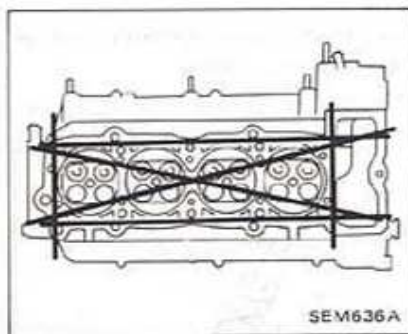

SEM636A

If beyond the specified limit, correct with a surface grinder.

Surface grinding limit:

The grinding limit of cylinder head is determined by the cylinder block grinding.

Depth of cylinder head grinding is "A"
Depth of cylinder block grinding is "B"

The limit is as follows:

$$A + B = 0.2 \text{ mm (0.008 in)}$$

VALVE GUIDE

VALVE GUIDE CLEARANCE

1. Check valve deflection.

Valve deflection:

Limit

0.2 mm (0.008 in)

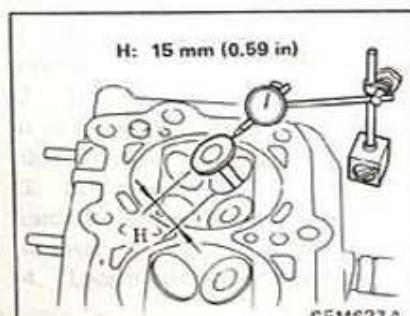

SEM637A

2. Measure the diameter of valve stem with a micrometer in three places; top, center and bottom.

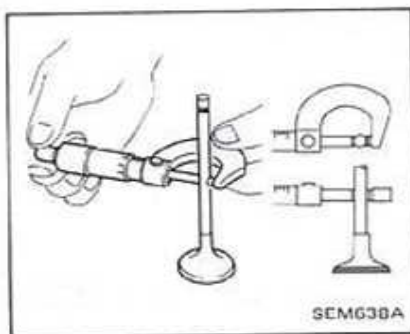

SEM638A

3. Measure valve guide bore using inside dial gauge.

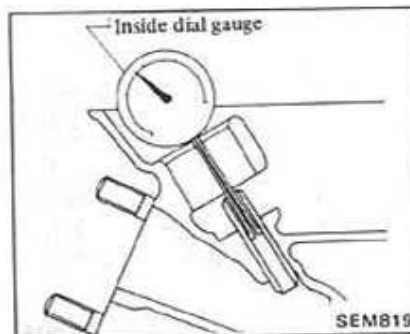

SEM819

4. Subtract the highest reading of valve stem diameter from valve guide bore to obtain the stem to guide clearance.

Stem to guide clearance:

Intake

0.025 - 0.055 mm
(0.0010 - 0.0022 in)

Exhaust

0.040 - 0.077 mm
(0.0016 - 0.0030 in)

VALVE SEAT INSERTS

Check valve seat inserts for any evidence of pitting at valve contact surface, and reseat if worn out excessively.

Correct valve seat surface with Tool and grind with a grinding compound.

- When repairing valve seat, check valve and valve guide for wear beforehand. Then correct valve seat.
- The cutting should be done with

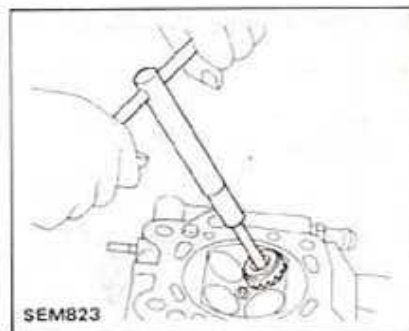

SEM823

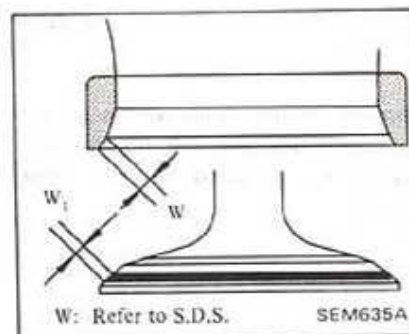

SEM635A

CAMSHAFT AND CAMSHAFT BEARING

CAMSHAFT BEARING CLEARANCE

1. Clean camshaft journal and bearing.
2. Place plastigage across journal.
3. Install caps and tighten.

T : 14 - 18 N·m
(1.4 - 1.8 kg·m,
10 - 13 ft·lb)

4. Remove caps and measure plastigage.

Max. tolerance of camshaft bearing clearance:

0.1 mm (0.004 in)

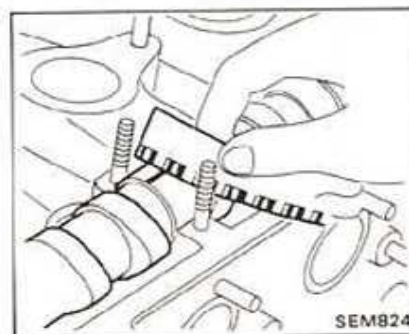

SEM824

5. Measure camshaft journal diameter and cylinder head camshaft journal diameter.

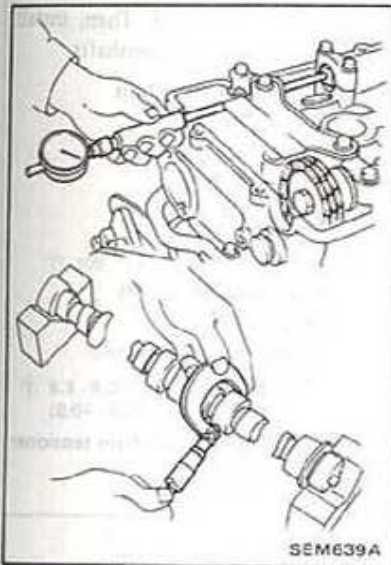

CAMSHAFT BEND

Camshaft bend:
Limit 0.05 mm (0.0020 in)

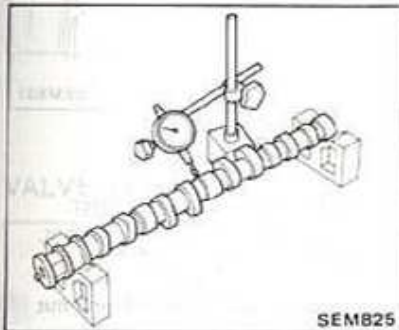

CAMSHAFT CAM HEIGHT

Cam height:
42.835 - 42.865 mm
(1.6864 - 1.6876 in)
Wear limit:
0.1 mm (0.004 in)

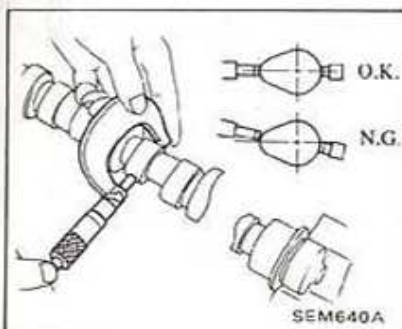

CAMSHAFT END PLAY

End play:
Limit 0.3 mm (0.012 in)

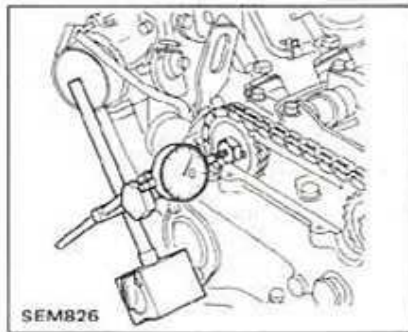

VALVE

- When valve head has been worn down to 0.5 mm (0.020 in) in margin-thickness, replace the valve.

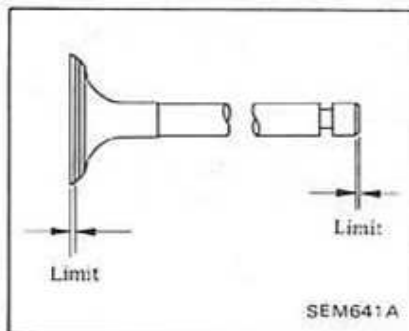

- Stem worn down: Limit 0.2 mm (0.008 in)

VALVE SPRING

1. Check valve spring for squareness using a steel square and surface plate.

Out of square ("S"):

Outer

Limit 2.0 mm (0.079 in)

Inner

Limit 1.8 mm (0.071 in)

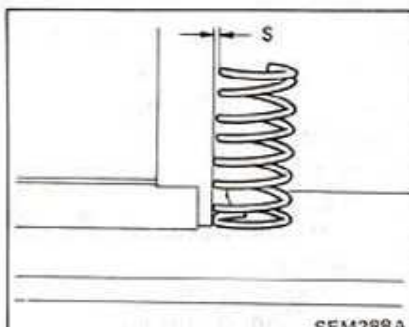

2. Measure the free length and the tension of each spring. Refer to S.D.S.

VALVE LIFTER

1. Measure outside diameter of valve lifter and inside diameter of valve lifter guide hole.

Valve lifter clearance:
0.025 - 0.075 mm
(0.0010 - 0.0030 in)

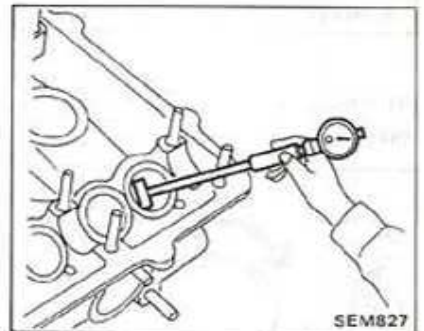

CYLINDER HEAD ASSEMBLY

1. Install valve and valve spring.
(1) Install valve spring seat and valve oil seal using Tool.

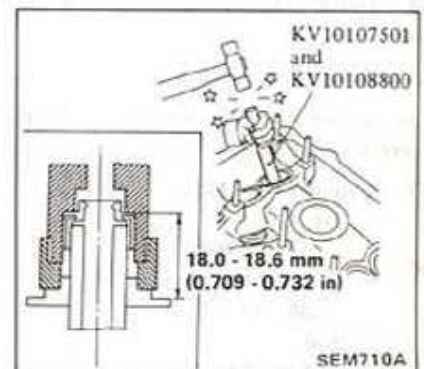

(2) Install valve, valve spring inner and outer, valve spring retainer, using Tool.

a. When installing valve, apply engine oil on valve stem and lip of valve oil seal.

b. Check whether valve face is free from foreign matter.

(3) Install valve cap and valve lifter.

a. Pay particular attention not to damage valve lifter guide hole.

b. Apply engine oil on valve cap and outer wall of valve lifter.

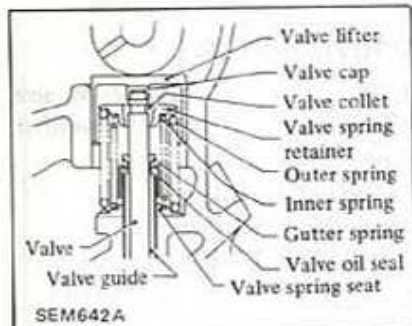

(4) Check valve lifter for smooth rotation.

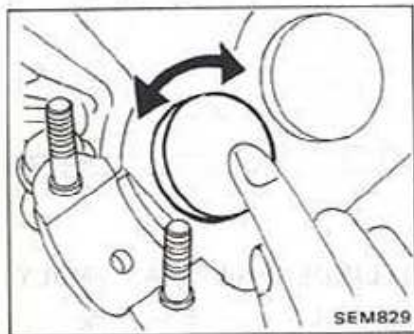

2. Install cylinder head onto cylinder block.

Always use new gasket.

3. Tighten cylinder head bolts in the reverse order of removal.

- ⊕ : Cylinder head bolt
- 1st
 - 49 - 59 N·m
 - (5.0 - 6.0 kg·m,
 - 36 - 43 ft·lb)
- 2nd
 - 118 - 127 N·m
 - (12.0 - 13.0 kg·m,
 - 87 - 94 ft·lb)

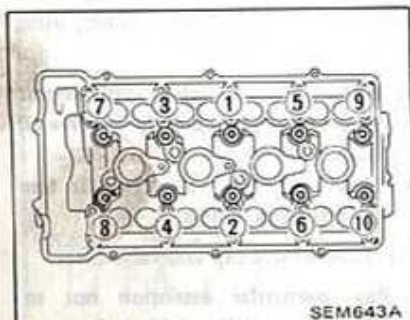

3rd (Retighten after loosening to 1st torque)

- 118 - 127 N·m
- (12.0 - 13.0 kg·m,
- 87 - 94 ft·lb)

4. Tighten chain guide C upper bolt.
5. Install camshafts and tighten camshaft bracket nuts with chain guide A in the reverse order of removal in two or three stages.

- ⊕ : Camshaft bracket nut
- 14 - 18 N·m
- (1.4 - 1.8 kg·m,
- 10 - 13 ft·lb)

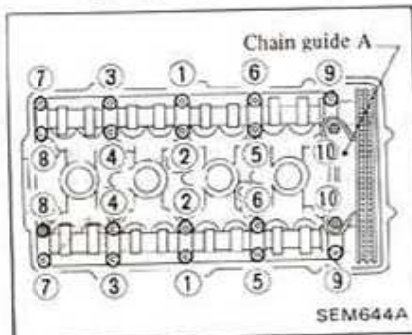

a. Install camshafts so that No. 1 cams are at top dead center.

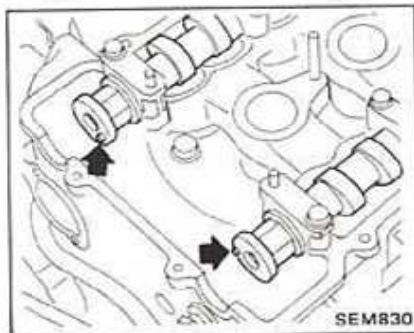

b. Apply engine oil on cam, camshaft journal, camshaft bearing and valve lifter upper surface.

6. Adjust intake and exhaust valve clearance. Refer to Adjusting Intake And Exhaust Valve Clearance in section MA.

- Valve clearance [Cold]:
- at 20°C (68°F)
- Intake
 - 0.20 - 0.26 mm
 - (0.0079 - 0.0102 in)
- Exhaust
 - 0.28 - 0.34 mm
 - (0.0110 - 0.0134 in)

Valve clearances should ultimately be adjusted to the hot values.

7. Set timing chain on camshaft sprockets by aligning each mark scribed before removal. Then, install camshaft sprockets to camshafts.

- ⊕ : Camshaft sprocket bolt
- 127 - 177 N·m
- (13.0 - 18.0 kg·m,
- 94 - 130 ft·lb)

8. Install chain tensioner A.

- ⊕ : Chain tensioner A bolt
- 6.3 - 8.3 N·m
- (0.64 - 0.85 kg·m,
- 4.6 - 6.1 ft·lb)

Before installation, fill chain tensioner A with engine oil.

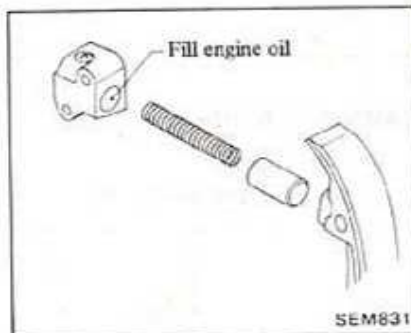

9. Install chain tensioner cover.
10. Install rubber plug with sealant.
11. Install valve rocker cover.

- ⊕ : Valve rocker cover bolt and nut
- 9.1 - 11.8 N·m
- (0.93 - 1.2 kg·m,
- 6.7 - 8.7 ft·lb)

- a. Rocker cover bolts should be tightened in criss-cross fashion.
- b. Always use new rocker cover gasket.

12. Install outer parts.

CAMSHAFT AND JACK SHAFT DRIVE

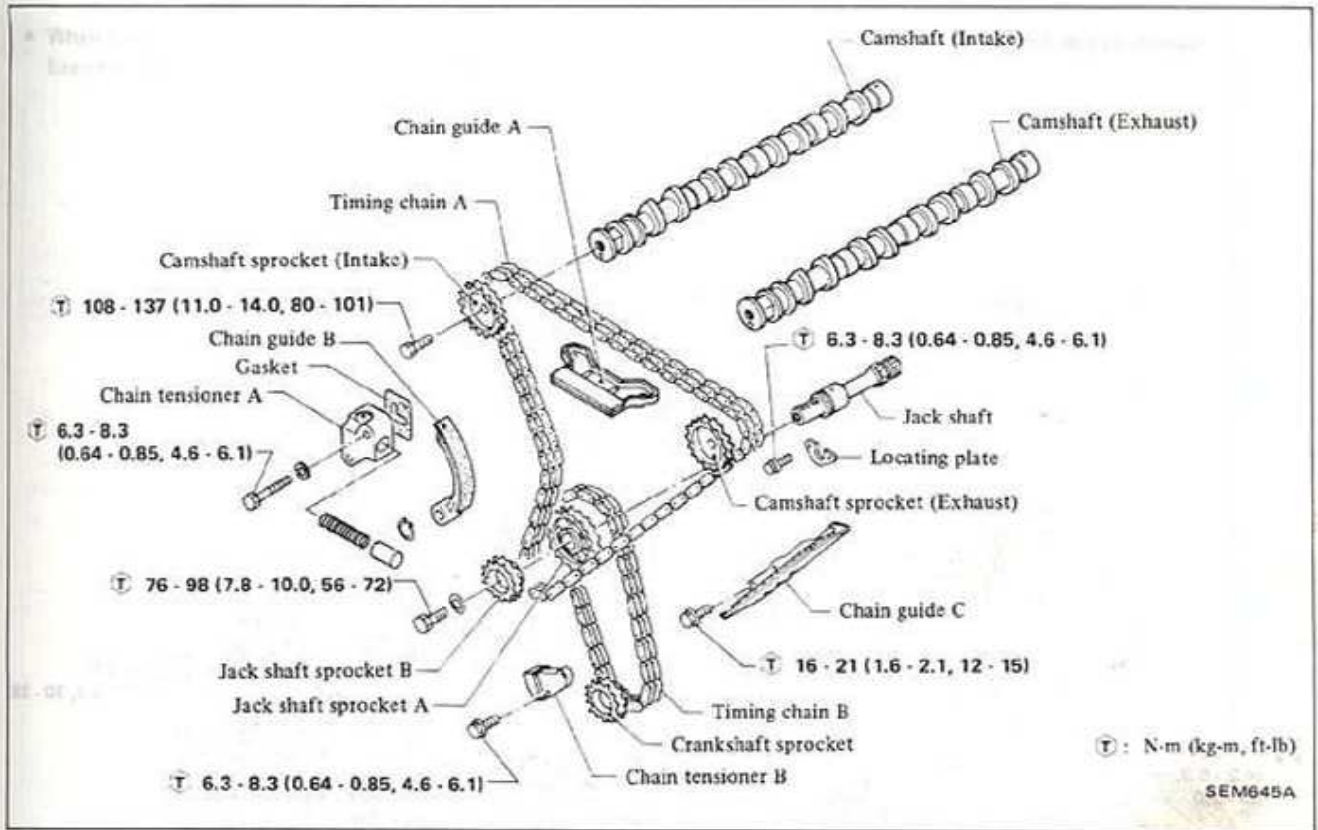

VALVE TIMING

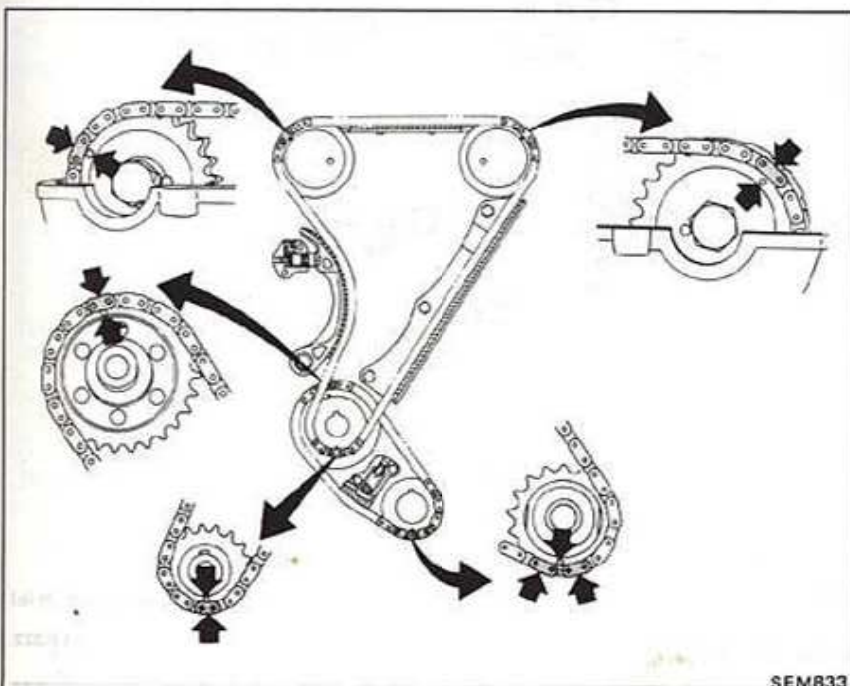

CHAIN TENSIONER

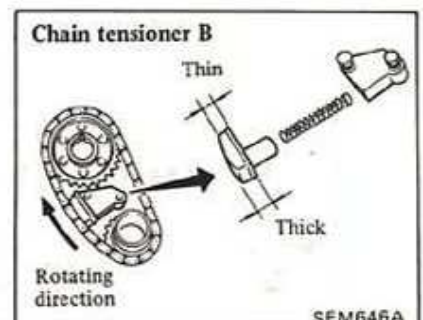
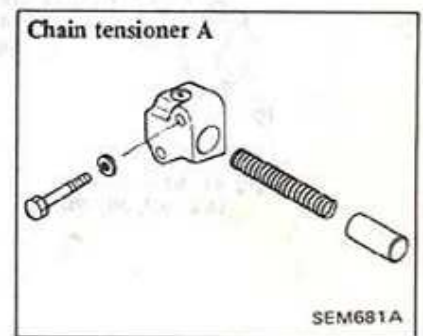

ENGINE REMOVAL

FJ20E

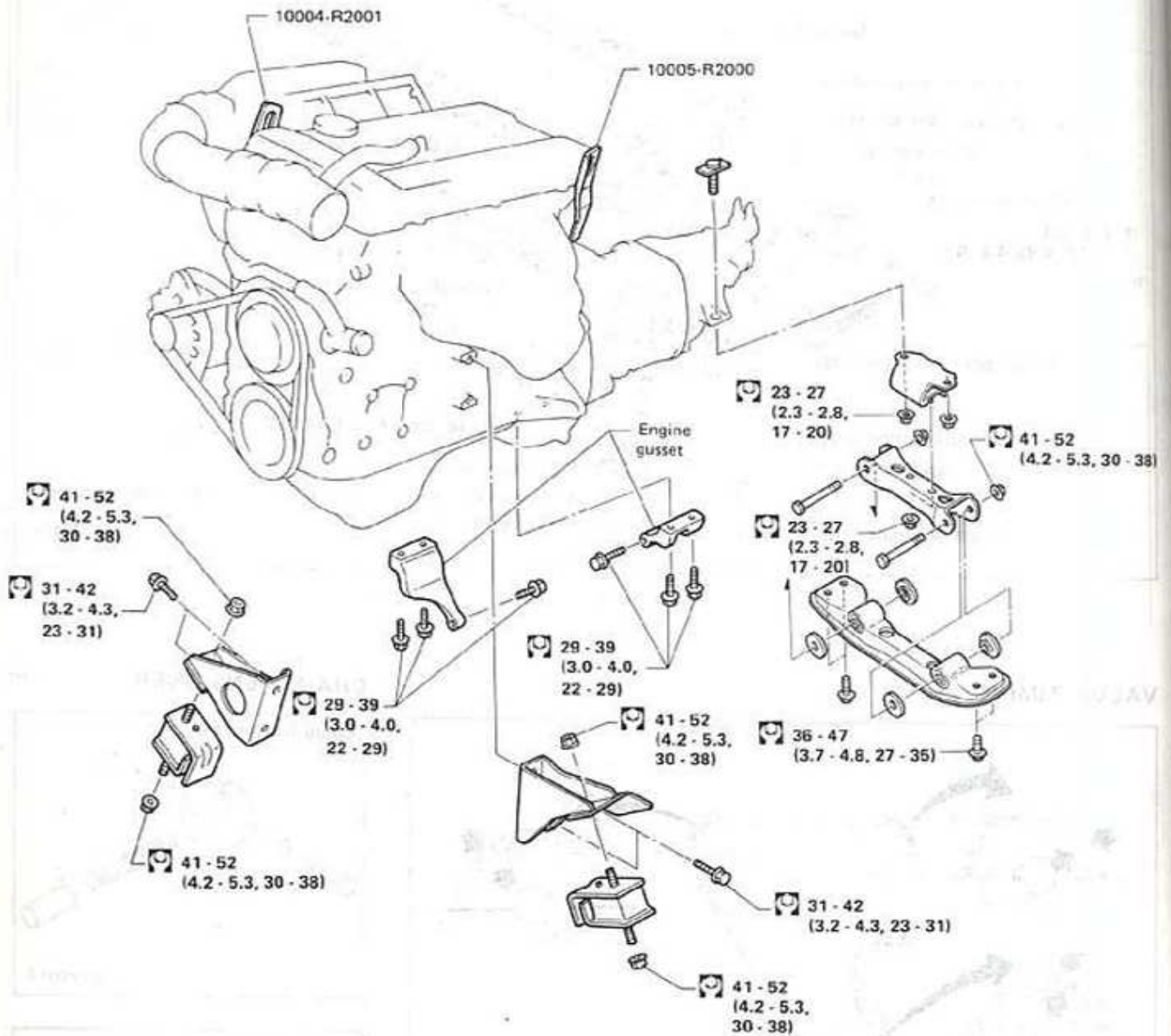

⊕ : N·m (kg·m, ft·lb)

CYLINDER BLOCK, CRANKSHAFT AND PISTON

- When installing sliding parts such as bearings, be sure to apply engine oil on the sliding surfaces.
- Use new packings and oil seals.
- Be careful not to damage oil seal.

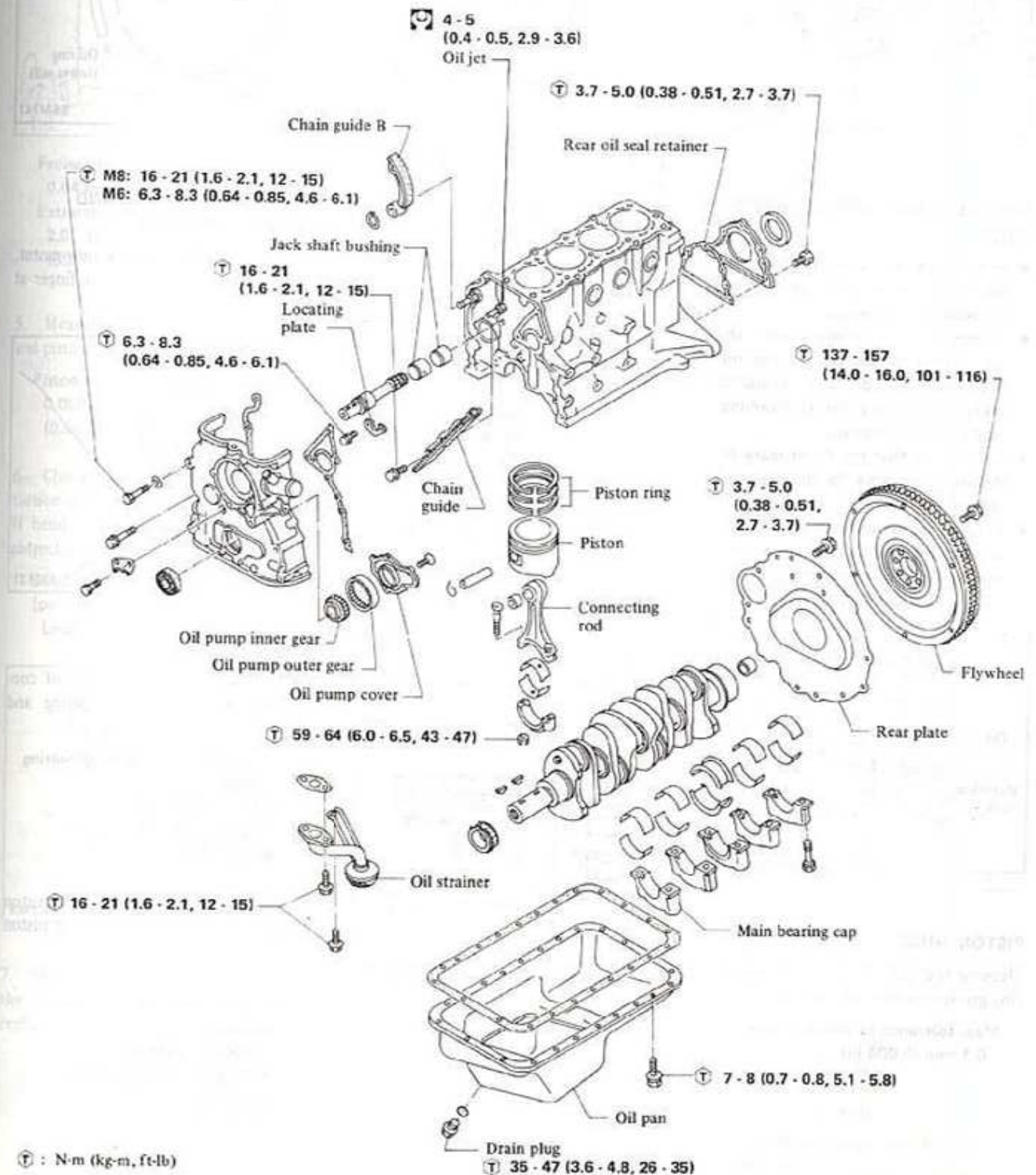

ENGINE ATTACHMENT

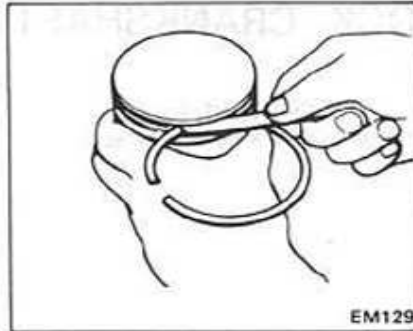
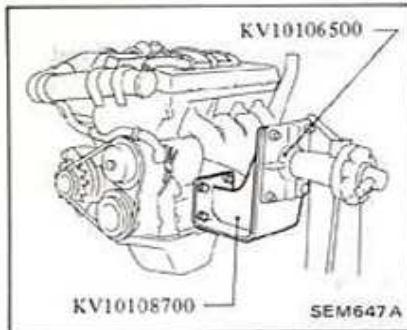

- Set piston rings as shown below.

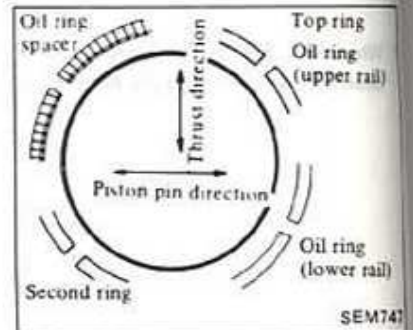

PISTON AND CONNECTING ROD

- Piston can be easily removed by scraping carbon off top face of cylinder with a scraper.
- Numbers are stamped on the connecting rod and cap corresponding to each cylinder. Care should be taken to avoid a wrong combination including bearing.
- Arrange so that the front mark on piston head faces to the front of engine.
- Arrange so that oil hole of connecting rod big end is directed toward the right side of cylinder block.

Measure ring gap with a feeler gauge, placing ring squarely in cylinder using piston at upper or lower part of cylinder.

Max. tolerance of ring gap:
1.0 mm (0.039 in)

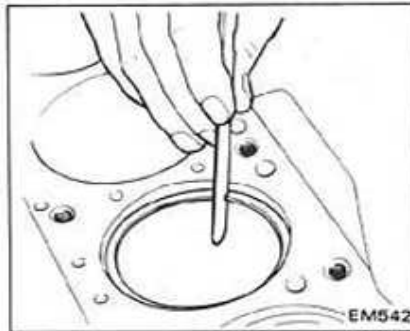

PISTON, PISTON PIN AND CONNECTING ROD

1. Check for smooth movement, pushing piston pin with a finger at room temperature.

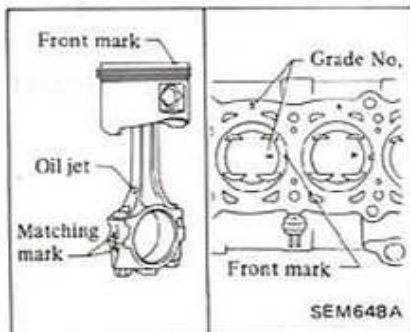
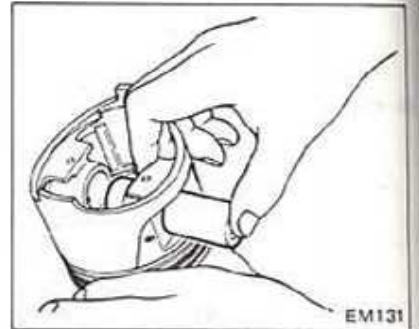

Install piston rings so that stamped mark on ring faces upward.

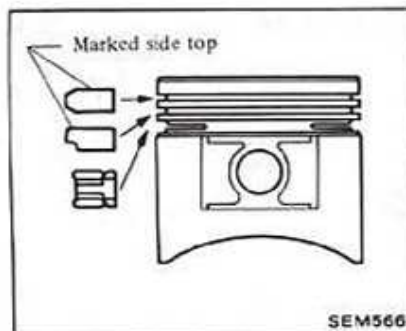

2. Measure inside diameter of connecting rod small end bearing and outer diameter of piston pin.

Connecting rod small end bearing clearance:
0.004 - 0.017 mm
(0.0002 - 0.0007 in) at
20°C (68°F)

3. Measure inner diameter of piston pin hole and outer diameter of piston pin.

Piston pin to piston pin hole clearance:
-0.005 - 0.004 mm
(-0.0002 - 0.0002 in) at
20°C (68°F)

PISTON RING

Measure the side clearance of rings in ring grooves as each ring is installed.

Max. tolerance of side clearance:
0.1 mm (0.004 in)

4. Measure the extracting force by pulling feeler gauge straight upward.

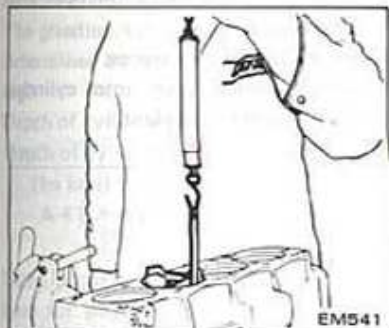

Feeler gauge thickness:
0.04 mm (0.0016 in)
Extracting force:
2.0 - 14.7 N
(0.2 - 1.5 kg, 0.4 - 3.3 lb)

5. Measure cylinder bore diameter and piston skirt diameter.

Piston to cylinder wall clearance:
0.050 - 0.070 mm
(0.0020 - 0.0028 in)

6. Check connecting rod for bend or torsion using a connecting rod aligner. If bend or torsion exceeds the limit, correct or replace.

Bend and torsion
[per 100 mm (3.94 in) length]:
Less than 0.05 mm (0.0020 in)

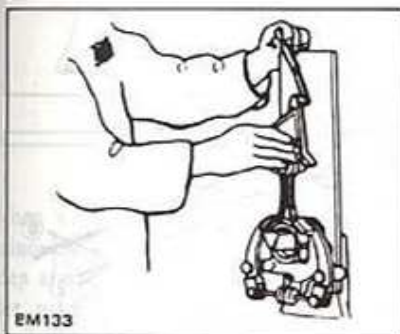

EM133

7. Measure the thrust clearance. If the measured value exceeds the limit, replace such connecting rod.

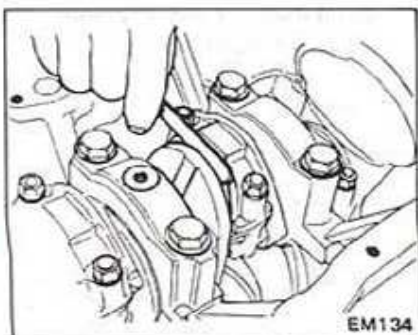

EM134

CAUTION:

Connecting rod with same weight tolerance is available only as a set of four.

CONNECTING ROD BEARING

Measure connecting rod bearing clearance using plastigage.

1. Remove connecting rod caps.
2. Clean crankshaft journal and bearing.
3. Place plastigage across journal.
4. Install caps and tighten.

ⓘ : Connecting rod bearing cap
59 - 64 N·m
(6.0 - 6.5 kg·m,
43 - 47 ft·lb)

5. Remove cap and measure plastigage.

Max. tolerance of connecting rod bearing clearance:
0.10 mm (0.0039 in)

CAUTION:

Do not turn crankshaft or connecting rod while the plastigage is being inserted.

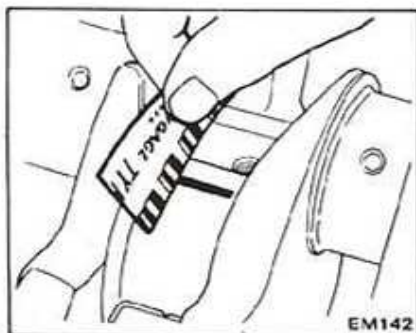

EM142

CRANKSHAFT

CRANK JOURNAL AND PIN

1. Check crankshaft journals and pins for score, bias, wear or cracks. If faults are minor, correct with fine crocus cloth.
2. Check journals and crank pins with a micrometer for taper and out-of-round. Measurement should be taken along journals for taper and around journals for out-of-round. If out-of-round or taper exceeds the specified limit, replace or repair.

Out-of-round (X-Y) and
Taper (A-B):
Less than 0.01 mm (0.0004 in)

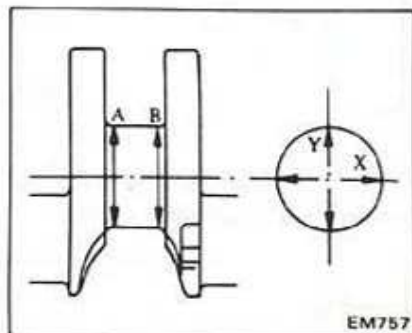

EM757

CRANKSHAFT RUNOUT

Check crankshaft runout.

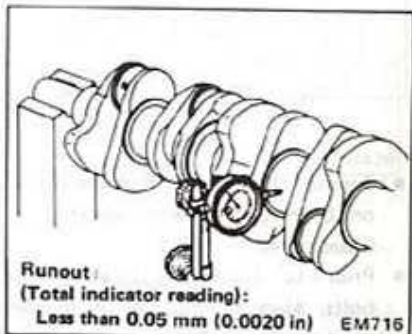

Runout:
(Total indicator reading):
Less than 0.05 mm (0.0020 in) EM715

MAIN BEARING

Measure main bearing clearance using plastigage.

ⓘ : Main bearing cap
83 - 98 N·m
(8.5 - 10.0 kg·m,
61 - 72 ft·lb)

Max. tolerance of main bearing clearance:
0.10 mm (0.0039 in)

CRANKSHAFT INSTALLATION

1. Set upper main bearings in the proper position on cylinder block.

- Only center bearing (No. 3) is a flange type.
- Front bearing (No. 1) is also the same type as rear bearing (No. 5).
- Other inter bearings, except center bearing, are the same type.

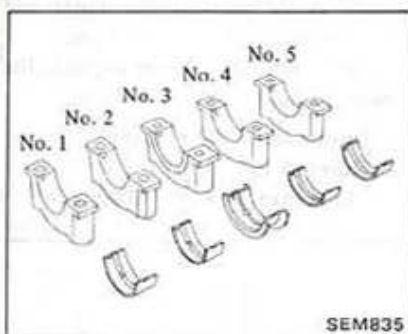

2. Install main bearing cap and tighten bolts to specified torque.

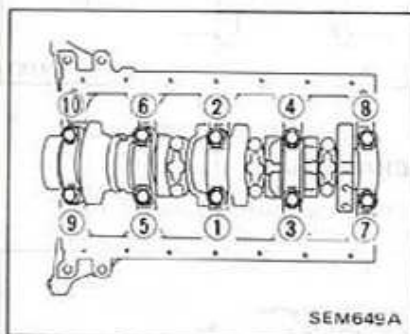

- Arrange the parts so that the figure on bearing cap faces toward the water pump.
- Prior to tightening bearing cap bolts, place bearing cap in proper position by shifting crankshaft in the axial direction.
- Tighten bearing cap bolts gradually in separating two to three stages and in sequence outwardly from center bearing.
- After securing bearing cap bolts, ascertain that crankshaft turns smoothly by hand.

3. Measure crankshaft free end play at the center bearing:

Crankshaft free end play limit:
0.30 mm (0.0118 in)

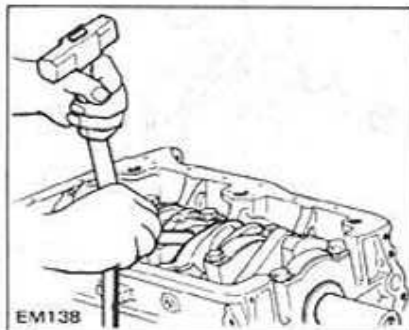
**JACK SHAFT AND JACK SHAFT BUSHING****JACK SHAFT FREE END PLAY**

Measure jack shaft free end play.

Free end play:
0.045 - 0.105 mm
(0.0018 - 0.0041 in)

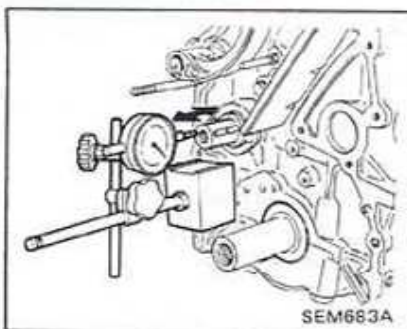
**JACK SHAFT BUSHING CLEARANCE**

Journal diameters should be checked with a micrometer, and bushings with an inside dial gauge. Measurements should then be compared to determine whether bushings are worn.

Max. tolerance of jack shaft bushing clearance:
0.15 mm (0.0059 in)

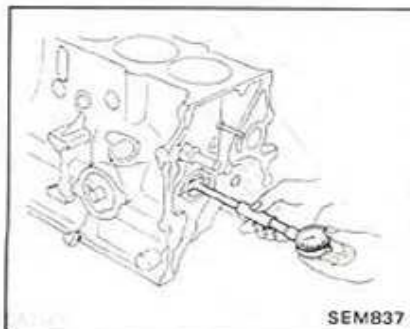
**REPLACING JACK SHAFT BUSHING**

- Align cylinder block oil hole and bushing oil hole.
- Check bushing clearance.
- Install welch plug into cylinder block, applying sealant.

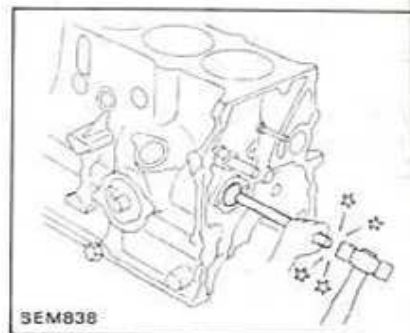
**CYLINDER BLOCK****CYLINDER BLOCK DISTORTION AND WEAR**

Warpage of surface:
Less than 0.1 mm (0.004 in)

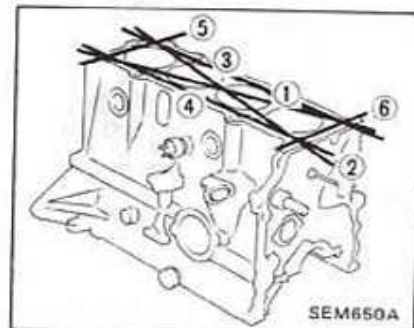
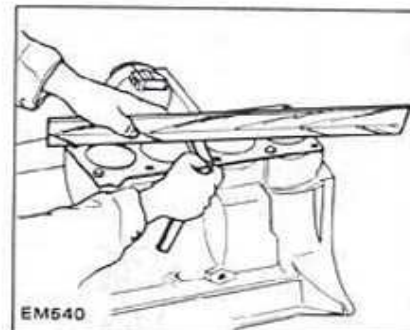

If beyond the specified limit, correct with surface grinder.

Surface grinding limit:

The grinding limit of cylinder block is determined by the cylinder head grinding.

Depth of cylinder head grinding is A
Depth of cylinder block grinding is B

The limit is as follows:

$$A + B = 0.2 \text{ mm (0.008 in)}$$

Using a bore gauge, measure cylinder bore for wear, out-of-round or taper. Refer to S.D.S.

Out-of-round X-Y
Taper A-B

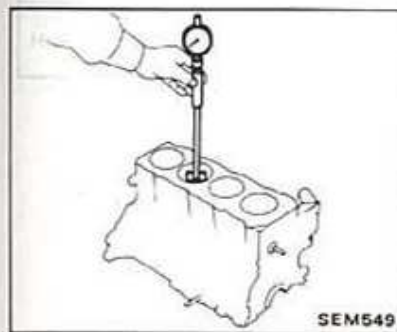
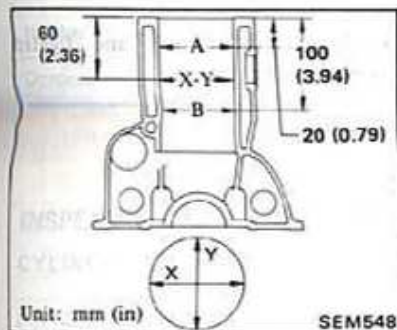

When wear, taper or out-of-round is minor and within the limit, remove the step at the topmost portion of cylinder using a ridge reamer or other similar tool.

CYLINDER BORING

When any cylinder needs boring, all other cylinders must also be bored at the same time.

Determining bore size

1. Determine piston oversize according to amount of cylinder wear. Refer to S.D.S.
2. The size to which cylinder must be honed is determined by adding piston-to-cylinder clearance to the piston skirt diameter.

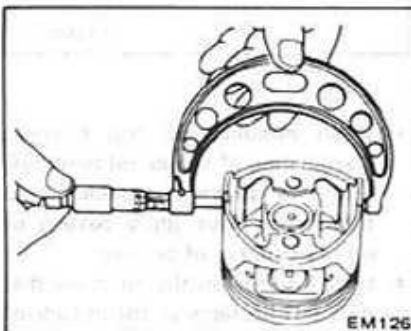

Rebored size calculation:

$$D = A + B - C$$

$$= A + [0.030 \text{ to } 0.050 \text{ mm (0.0012 to 0.0020 in)}]$$

where,

- D : Honed diameter
- A : Skirt diameter as measured
- B : Piston-to-wall clearance
- C : Honing allowance 0.02 mm (0.0008 in)

Boring

1. Install main bearing caps in place, and tighten to the specified torque to prevent distortion of the cylinder bores in final assembly.
2. Hone the cylinders to the required size referring to S.D.S.

FRONT COVER

Before installing front cover, align locating notches.

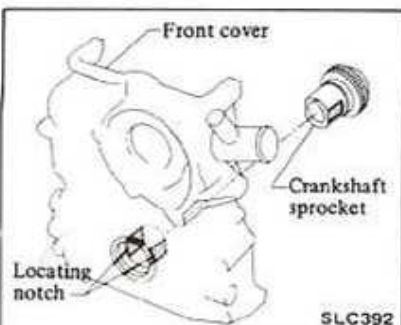

APPLYING SEALANT

Use sealant to eliminate water and oil leaks. Do not apply too much sealant. Part requiring sealant is:

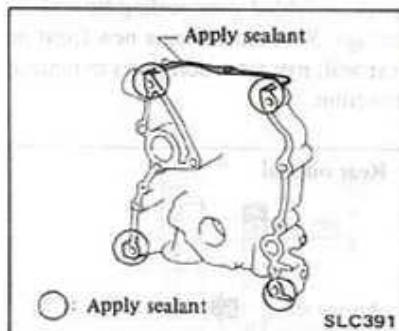

Ensure that O-ring is provided.

FLYWHEEL

Measure runout of the clutch disc contact surface with a dial gauge.

Runout

(Total indicator reading):
Less than 0.1 mm (0.004 in)

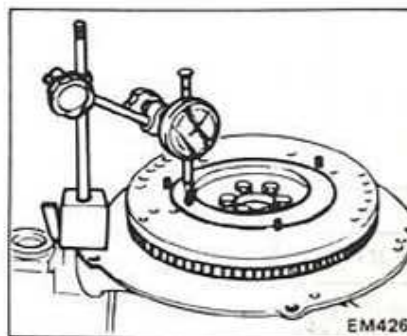

Check tooth surfaces of ring gear for flaws or wear.

Install ring gear on flywheel, heating ring gear to about 180 to 220°C (356 to 428°F).

OIL SEAL

- It is good practice to renew oil seal whenever engine is overhauled.

Check front, and rear oil seals for worn or folded over sealing lip and oil leakage. When installing a new front or rear seal, pay attention to its mounting direction.

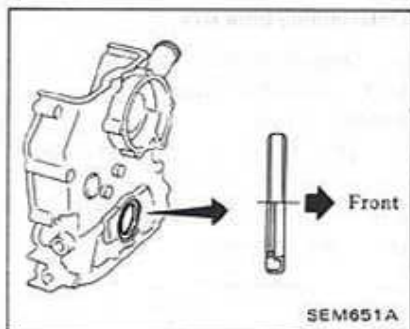
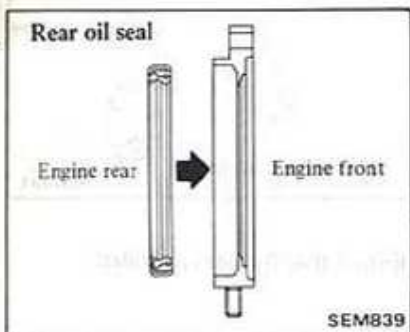

- When installing oil seal retainer, give coating of engine oil to mating shaft to prevent scratches and folded lip. Also apply coating of oil to periphery of oil seal.
- Install oil seal in the direction that dust seal lip faces to the outside of crankcase.

DISTRIBUTOR

1. Make sure No. 1 piston is at top dead center.
2. Align distributor gear with the mark on the shaft.

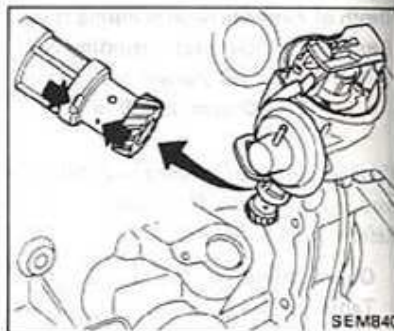

3. Install distributor and tighten fixing plate bolt.

SERVICE DATA AND SPECIFICATIONS

GENERAL SPECIFICATIONS

Destination	Except for Europe & Hong Kong	For Europe & Hong Kong
Cylinder arrangement	4, in-line	
Displacement	cm ³ (cu in)	1,990 (121.43) 1,991 (121.49)
Bore and stroke	mm (in)	89 x 80 (3.50 x 3.15)
Valve arrangement	D.O.H.C.	
Firing order	1-3-4-2	
Number of piston rings		
Compression	2	
Oil	1	
Number of main bearings	5	
Compression ratio	9.1	9.5

INSPECTION AND ADJUSTMENT CYLINDER HEAD

Unit: mm (in)

	Standard	Limit
Head surface flatness	Less than 0.05 (0.0020)	0.1 (0.004)

VALVE

Unit: mm (in)

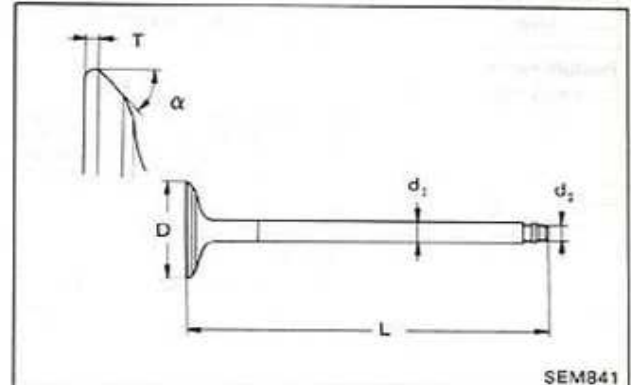

Valve head diameter "D"	Intake	34.5 (1.358)
	Exhaust	30.0 (1.181)
Valve length "L"	Intake	125.01 - 125.51 (4.922 - 4.941)
	Exhaust	124.96 - 125.46 (4.920 - 4.939)
Valve stem diameter "d ₁ "	Intake	6.960 - 6.975 (0.2740 - 0.2746)
	Exhaust	6.938 - 6.960 (0.2731 - 0.2740)
Valve stem end diameter "d ₂ "	Intake & Exhaust	5.572 - 5.590 (0.2194 - 0.2201)
Valve seat angle "α"		45° 15' - 45° 45'
Valve clearance (Hot)	Intake	0.30 (0.012)
	Exhaust	0.35 (0.014)
Valve clearance (Cold)*	Intake	0.20 - 0.26 (0.008 - 0.010)
	Exhaust	0.28 - 0.34 (0.011 - 0.013)

*Cold: Used as approximate values during engine assembly, clearances should ultimately be adjusted to the above hot values; refer to section MA for procedure.

Valve lifter

Unit: mm (in)

	Standard	Limit
Valve lifter: outer diameter	33.950 - 33.975 (1.3366 - 1.3376)	-
Cylinder head valve lifter guide hole inner diameter	34.000 - 34.025 (1.3386 - 1.3396)	-
Valve lifter guide hole clearance [Oil clearance]	0.025 - 0.075 (0.0010 - 0.0030)	-

Valve spring

		Standard
Free length	mm (in)	
	Outer	45.07 (1.7744)
	Inner	41.66 (1.6402)
Pressure height	mm/N (mm/kg, in/lb)	
	Outer	28.7/324.6 (28.7/33.1, 1.130/73.0)
	Inner	25.2/172.6 (25.2/17.6, 0.992/38.8)
Assembly height	mm/N (mm/kg, in/lb)	
	Outer	37.2/155.9 (37.2/15.9, 1.465/35.1)
	Inner	33.7/83.65 (33.7/8.53, 1.327/18.81)
Out of square	mm (in)	
	Outer	2.0 (0.079)
	Inner	1.8 (0.071)

Valve guide

Unit: mm (in)

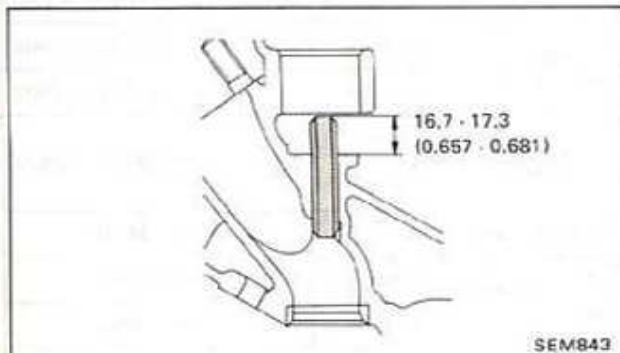

Valve guide		12.033 - 12.044
Outer diameter		(0.4737 - 0.4742)
Valve guide		7.000 - 7.015
Inner diameter (Finished size)		(0.2756 - 0.2762)
Cylinder head valve guide hole diameter		11.970 - 11.988
		(0.4713 - 0.4720)
Interference fit of valve guide		0.045 - 0.074
		(0.0018 - 0.0029)
Stem to guide clearance	Intake	0.025 - 0.055
	Exhaust	0.040 - 0.077
		(0.0010 - 0.0022)
		0.040 - 0.077
		(0.0016 - 0.0030)

Valve seat

Unit: mm (in)

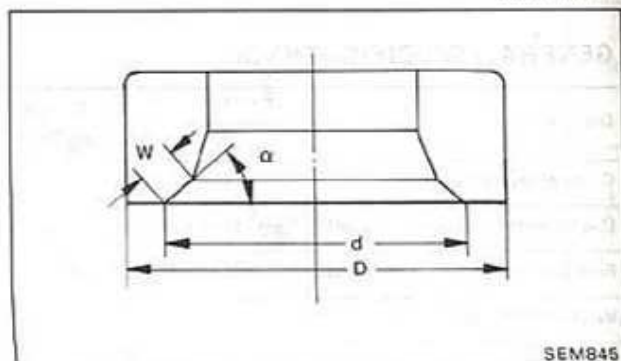

Contacting face angle "α"		45°
Contacting width "W"	Intake	1.63 (0.0642)
	Exhaust	1.55 (0.0610)
Finished diameter "d"	Intake	33.9 - 34.1
	Exhaust	(1.335 - 1.343)
	Exhaust	29.4 - 29.6
		(1.157 - 1.165)
Outer diameter "D"	Intake	36.780 - 36.796
	Exhaust	(1.4480 - 1.4487)
	Exhaust	33.080 - 33.096
		(1.3024 - 1.3030)
Cylinder head seat recess diameter	Intake	36.700 - 36.716
	Exhaust	(1.4449 - 1.4455)
	Exhaust	33.000 - 33.016
		(1.2992 - 1.2998)
Interference fit of seat insert		0.064 - 0.096
		(0.0025 - 0.0038)

CAMSHAFT AND CAMSHAFT BEARING

Unit: mm (in)

	Standard	Max. tolerance
Camshaft journal to bearing clearance	0.025 - 0.085 (0.0010 - 0.0033)	0.1 (0.004)
Inner diameter of camshaft bearing	32.000 - 32.021 (1.2598 - 1.2607)	-
Outer diameter of camshaft journal	31.936 - 31.975 (1.2573 - 1.2589)	-
Camshaft bend [Total indicator reading]	Less than 0.05 (0.0020)	
Camshaft end play	Less than 0.3 (0.012)	

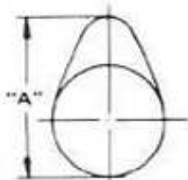

EM671

Cam height "A"	42.835 - 42.865 (1.6864 - 1.6876)
Wear limit of cam height	0.1 (0.004)

Valve timing

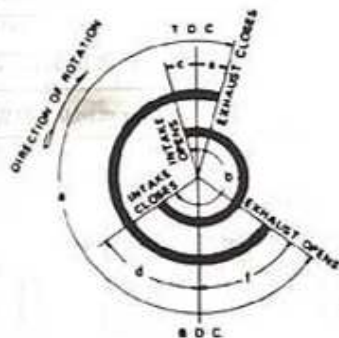

EM120

Unit: degree

a	b	c	d	e	f
256°	256°	23°	53°	11°	65°

JACK SHAFT AND JACK SHAFT BUSHING

Unit: mm (in)

		Standard	Max. tolerance
Jack shaft journal to bushing clearance	Front	0.025 - 0.089 (0.0010 - 0.0035)	0.15 (0.0059)
	Rear	0.020 - 0.074 (0.0008 - 0.0029)	0.15 (0.0059)
Inner diameter of jack shaft bushing	Front	34.025 - 34.054 (1.3396 - 1.3411)	-
	Rear	29.020 - 29.053 (1.1425 - 1.1438)	-
Outer diameter of jack shaft journal	Front	33.975 - 34.000 (1.3376 - 1.3386)	-
	Rear	28.979 - 29.000 (1.1409 - 1.1417)	-
Jack shaft end play		0.045 - 0.105 (0.0018 - 0.0041)	

CYLINDER BLOCK

Unit: mm (in)

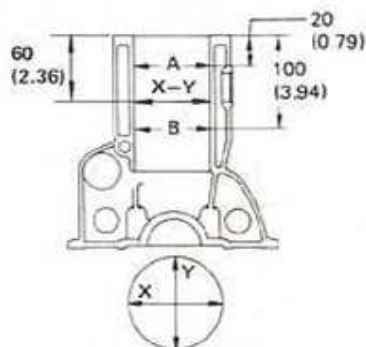

SEM548

	Standard	Limit
Surface flatness	Less than 0.05 (0.0020)	0.1 (0.0039)
Cylinder bore Inner diameter	89.000 - 89.050 (3.5039 - 3.5059)	-
Out-of-round (X-Y)	Less than 0.015 (0.0006)	
Taper (A-B)	Less than 0.015 (0.0006)	
Difference in inner diameter between cylinders	0.05 (0.0020)	

SERVICE DATA AND SPECIFICATIONS

FJ20E

PISTON, PISTON RING AND PISTON PIN

Piston

Unit: mm (in)

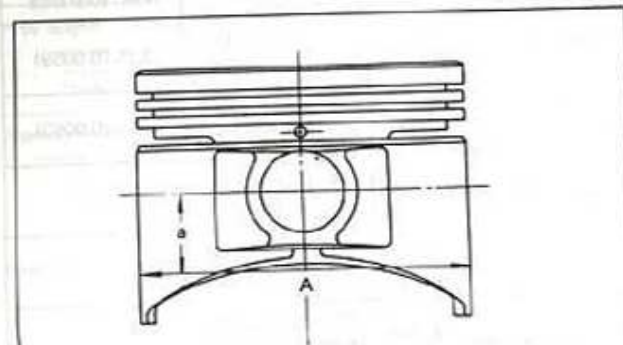

Piston skirt diameter "A" Standard	88.940 - 88.990 (3.5016 - 3.5035)
Oversize for service [0.5 (0.020)]	89.440 - 89.490 (3.5213 - 3.5232)
"a" dimension	11.0 (0.433)
Piston pin hole diameter	21.991 - 22.000 (0.8658 - 0.8661)
Piston clearance to cylinder block	0.050 - 0.070 (0.0020 - 0.0028)

Piston ring

Unit: mm (in)

	Standard	Limit
Side clearance		
Top	0.03 - 0.07 (0.0012 - 0.0028)	0.1 (0.004)
2nd	0.03 - 0.07 (0.0012 - 0.0028)	0.1 (0.004)
Oil	—	—
Ring gap		
Top	0.3 - 0.4 (0.012 - 0.016)	1.0 (0.039)
2nd	0.3 - 0.5 (0.012 - 0.020)	1.0 (0.039)
Oil (rail ring)	0.2 - 0.6 (0.008 - 0.024)	1.0 (0.039)

Piston pin

Unit: mm (in)

Piston pin outer diameter	21.991 - 22.000 (0.8658 - 0.8661)
Piston pin to piston clearance	-0.005 - 0.004 (-0.0002 - 0.0002) at 20°C [68°F]
Piston pin to connecting rod clearance	0.004 - 0.017 (0.0002 - 0.0007) at 20°C [68°F]

Connecting rod

Unit: mm (in)

Center distance	140.0 (5.512)
Bend, torsion [per 100 (3.94)]	
Standard	0.025 (0.0010)
Limit	0.05 (0.0020)
Piston pin bushing diameter	22.000 - 22.013 (0.8661 - 0.8667)
Big end play	
Standard	0.05 - 0.18 (0.0020 - 0.0071)
Limit	0.3 (0.012)

CRANKSHAFT

Unit: mm (in)

Main journal dia. "Dm"	54.942 - 54.955 (2.1631 - 2.1636)
Pin journal dia. "Dp"	49.961 - 49.974 (1.9670 - 1.9675)
Center distance "r"	40 (1.57)
Out-of-round (X-Y) and taper (A-B) Limit	Less than 0.01 (0.0004)
Bend (total indicator reading) Limit	Less than 0.05 (0.0020)
Free end play	
Standard	0.05 - 0.18 (0.0020 - 0.0071)
Limit	Less than 0.3 (0.012)

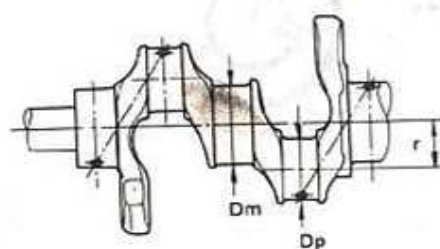

Out-of-round
Taper

X-Y
A-B

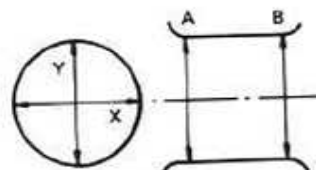

EM715

BEARING

Bearing clearance

Unit: mm (in)

	Standard	Limit
Main bearing clearance	0.035 - 0.075 (0.0014 - 0.0030)	0.1 (0.004)
Connecting rod bearing clearance	0.035 - 0.075 (0.0014 - 0.0030)	0.1 (0.004)

Main bearing undersize

Unit: mm (in)

	Crank main journal diameter "Dm"
Standard	54.942 - 54.955 (2.1631 - 2.1636)
Undersize 0.25 (0.0098)	54.692 - 54.705 (2.1532 - 2.1537)

MISCELLANEOUS COMPONENTS

Unit: mm (in)

Camshaft pulley Runout [Total indicator reading]	0.08 (0.0031)
Flywheel Runout [Total indicator reading]	0.1 (0.004)

TIGHTENING TORQUE

Engine outer parts

Unit	N·m	kg·m	ft·lb
Alternator bracket bolt			
Cylinder block	43 - 58	4.4 - 5.9	32 - 43
Front cover	30 - 40	3.1 - 4.1	22 - 30
Alternator to adjusting bar bolt	16 - 21	1.6 - 2.1	12 - 15
Clutch cover fixing bolt	16 - 21	1.6 - 2.1	12 - 15
Engine mounting bracket to cylinder block	30 - 40	3.1 - 4.1	22 - 30
Intake manifold nut	31 - 42	3.2 - 4.3	23 - 31
Intake manifold support bolt	30 - 40	3.1 - 4.1	22 - 30
Exhaust manifold nut	16 - 21	1.6 - 2.1	12 - 15
Throttle chamber bolt	16 - 21	1.6 - 2.1	12 - 15
Water pump bolt			
M6	6.3 - 8.3	0.64 - 0.85	4.6 - 6.1
M8	16 - 21	1.6 - 2.1	12 - 15
Cooling fan bolt	6.3 - 8.3	0.64 - 0.85	4.6 - 6.1
Spark plug	20 - 29	2.0 - 3.0	14 - 22
Compressor bracket bolt	30 - 40	3.1 - 4.1	22 - 30
Compressor to bracket	43 - 58	4.4 - 5.9	32 - 43
Crank pulley bolt	147 - 195	15.0 - 20.0	108 - 145
Distributor support bolt	6.3 - 8.3	0.64 - 0.85	4.6 - 6.1
Water outlet bolt	9.1 - 11.8	0.93 - 1.2	6.7 - 8.7

Engine internal parts

Unit	N·m	kg·m	ft·lb
Camshaft bracket nut	14 - 18	1.4 - 1.8	10 - 13
Camshaft sprocket bolt	108 - 137	11.0 - 14.0	80 - 101
Cylinder head			
1st	49 - 59	5.0 - 6.0	36 - 43
2nd	118 - 127	12.0 - 13.0	87 - 94
3rd (After loosening to 1st torque)	118 - 127	12.0 - 13.0	87 - 94
Main bearing cap bolt	83 - 98	8.5 - 10.0	61 - 72
Connecting rod nut	59 - 64	6.0 - 6.5	43 - 47
Jack shaft locating plate bolt	6.3 - 8.3	0.64 - 0.85	4.6 - 6.1
Jack shaft sprocket bolt	76 - 98	7.8 - 10.0	56 - 72
Chain guide bolt	16 - 21	1.6 - 2.1	12 - 15
Chain tensioner bolt	6.3 - 8.3	0.64 - 0.85	4.6 - 6.1
Front cover bolt			
M6	6.3 - 8.3	0.64 - 0.85	4.6 - 6.1
M8	16 - 21	1.6 - 2.1	12 - 15
Rear oil seal retainer bolt	3.7 - 5.0	0.38 - 0.51	2.7 - 3.7
Oil strainer bolt	16 - 21	1.6 - 2.1	12 - 15
Oil pan bolt	7 - 8	0.7 - 0.8	5.1 - 5.8
Oil pan drain plug	35 - 47	3.6 - 4.8	26 - 35
Flywheel bolt	137 - 157	14.0 - 16.0	101 - 116

ENGINE COMPONENTS (Outer parts)

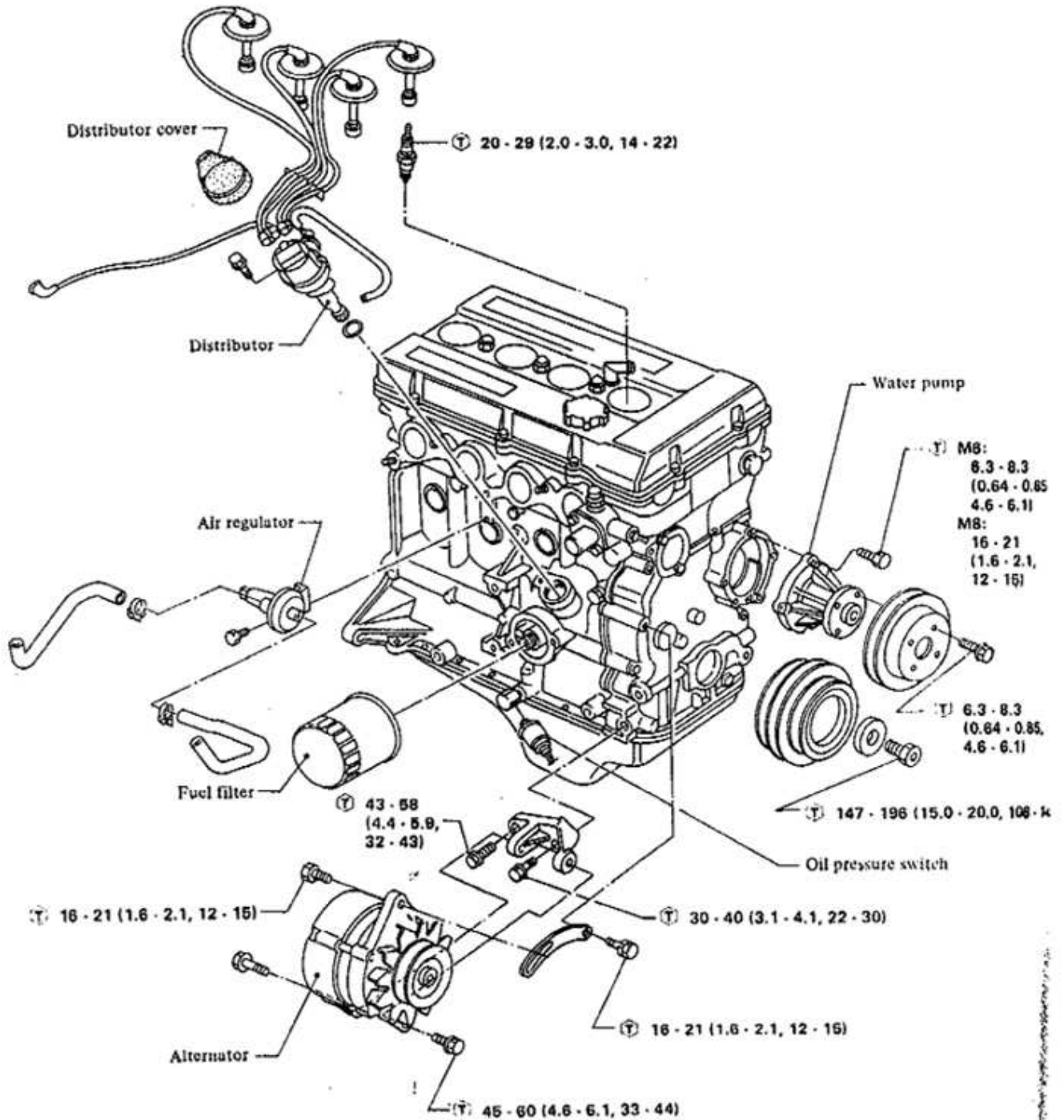

(T): N-m (kg-m, ft-lb)

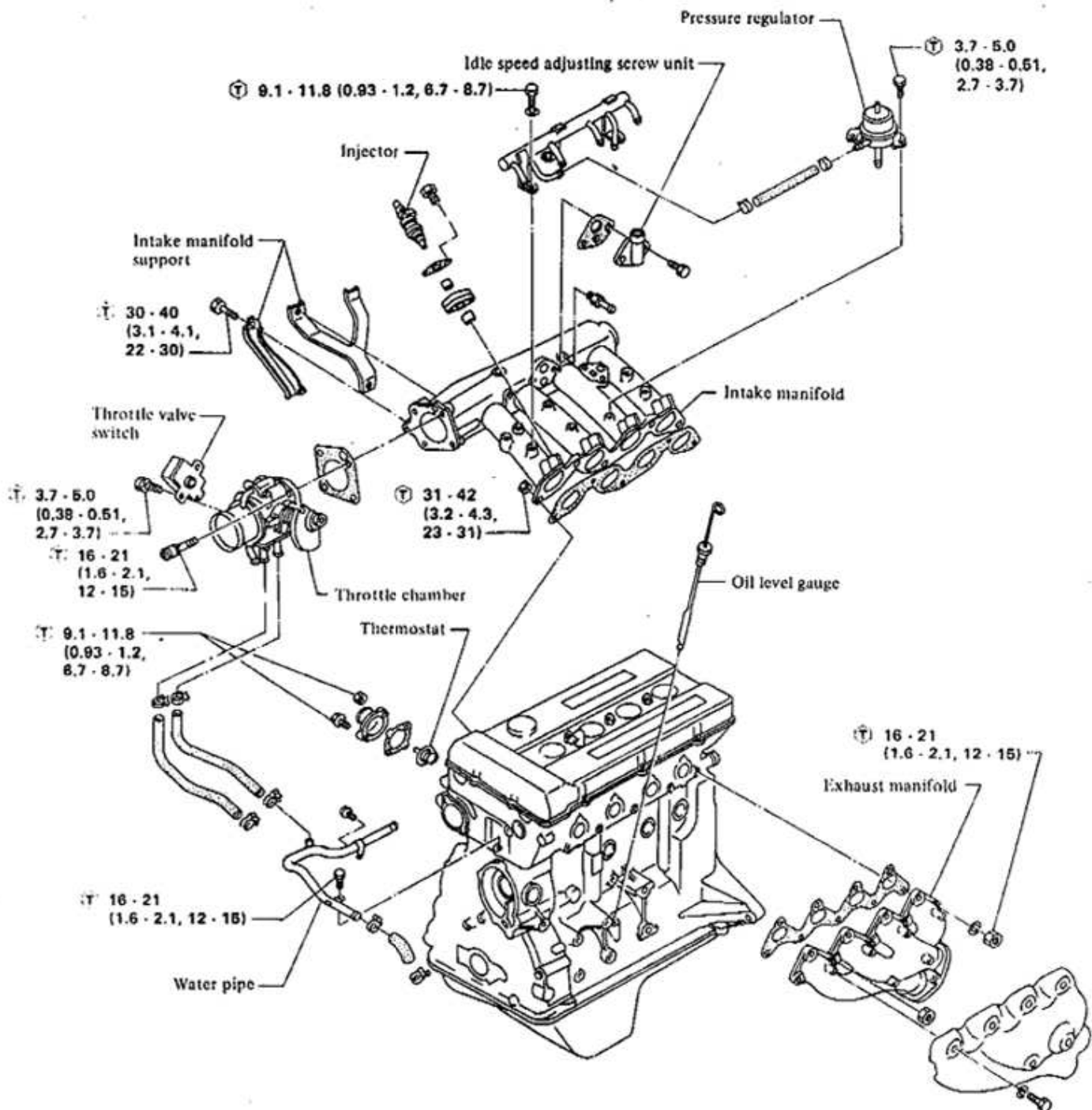

Ⓣ : N-m (kg-m, ft-lb)

SEM632A

PISTON, PISTON RING AND PISTON PIN

Piston

Unit: mm (in)

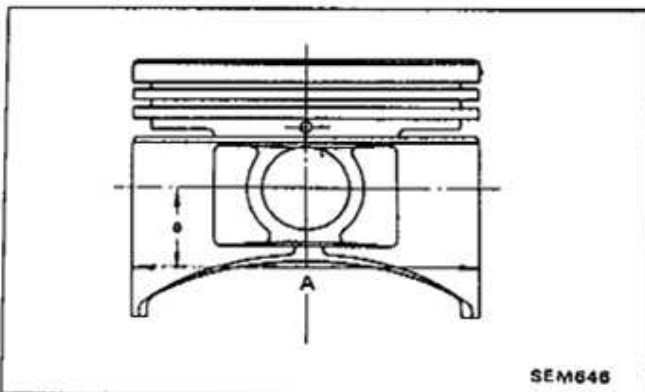

SEM646

Piston skirt diameter "A" Standard	88.940 - 88.990 (3.5016 - 3.5035)
Oversize for service (0.5 (0.020))	89.440 - 89.490 (3.5213 - 3.5232)
"a" dimension	11.0 (0.433)
Piston pin hole diameter	21.991 - 22.000 (0.8658 - 0.8661)
Piston clearance to cylinder block	0.050 - 0.070 (0.0020 - 0.0028)

Piston ring

Unit: mm (in)

	Standard	Limit
Side clearance		
Top	0.03 - 0.07 (0.0012 - 0.0028)	0.1 (0.004)
2nd	0.03 - 0.07 (0.0012 - 0.0028)	0.1 (0.004)
Oil	-	-
Ring gap		
Top	0.3 - 0.4 (0.012 - 0.016)	1.0 (0.039)
2nd	0.3 - 0.5 (0.012 - 0.020)	1.0 (0.039)
Oil (rail ring)	0.2 - 0.6 (0.008 - 0.024)	1.0 (0.039)

Piston pin

Unit: mm (in)

Piston pin outer diameter	21.991 - 22.000 (0.8658 - 0.8661)
Piston pin to piston clearance	-0.005 - 0.004 (-0.0002 - 0.0002) at 20°C (68°F)
Piston pin to connecting rod clearance	0.004 - 0.017 (0.0002 - 0.0007) at 20°C (68°F)

Connecting rod

Unit: mm (in)

Center distance	140.0 (6.51)
Bend, torsion (per 100 (3.94))	
Standard	0.025 (0.0010)
Limit	0.05 (0.0020)
Piston pin bushing diameter	22.000 - 22.013 (0.8661 - 0.8667)
Big end play	
Standard	0.05 - 0.18 (0.0020 - 0.0071)
Limit	0.3 (0.012)

CRANKSHAFT

Unit: mm (in)

Main journal dia. "Dm"	54.942 - 54.955 (2.1631 - 2.1636)
Pin journal dia. "Dp"	49.961 - 49.974 (1.9670 - 1.9675)
Center distance "r"	40 (1.57)
Out-of-round (X-Y) and taper (A-B) Limit	Less than 0.01 (0.0004)
Bend (total indicator reading) Limit	Less than 0.05 (0.0020)
Free end play	
Standard	0.05 - 0.18 (0.0020 - 0.0071)
Limit	Less than 0.3 (0.012)

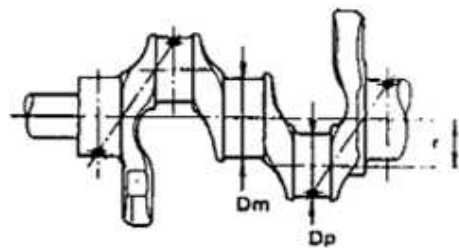

SEM646

Out-of-round X-Y
Taper A-B

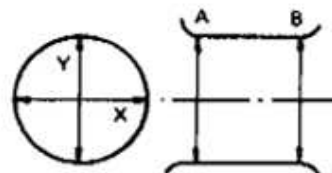

EM715

Valve spring

		Standard
Free length	mm (in)	
	Outer	46.07 (1.7744)
	Inner	41.66 (1.6402)
Pressure height	mm/N (mm/kg, in/lb)	
	Outer	28.7/324.6 (28.7/33.1, 1.130/73.0)
	Inner	25.2/172.6 (25.2/17.6, 0.992/38.8)
Assembly height	mm/N (mm/kg, in/lb)	
	Outer	37.2/165.9 (37.2/15.9, 1.465/35.1)
	Inner	33.7/83.65 (33.7/8.53, 1.327/18.81)
Out of square	mm (in)	
	Outer	2.0 (0.079)
	Inner	1.8 (0.071)

Valve guide

Unit: mm (in)

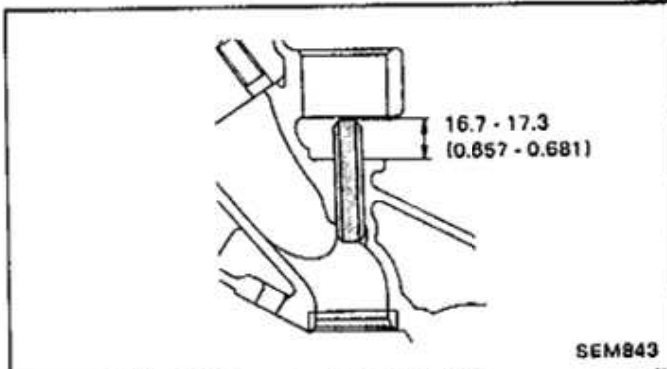

Valve guide		12.033 - 12.044 (0.4737 - 0.4742)
Outer diameter		
Valve guide		7.000 - 7.015 (0.2756 - 0.2762)
Inner diameter (Finished size)		
Cylinder head valve guide hole		11.970 - 11.988 (0.4713 - 0.4720)
diameter		
Interference fit of valve guide		0.045 - 0.074 (0.0018 - 0.0029)
Stem to guide	Intake	0.025 - 0.055 (0.0010 - 0.0022)
	Exhaust	0.040 - 0.077 (0.0016 - 0.0030)
clearance		

Valve seat

Unit: mm (in)

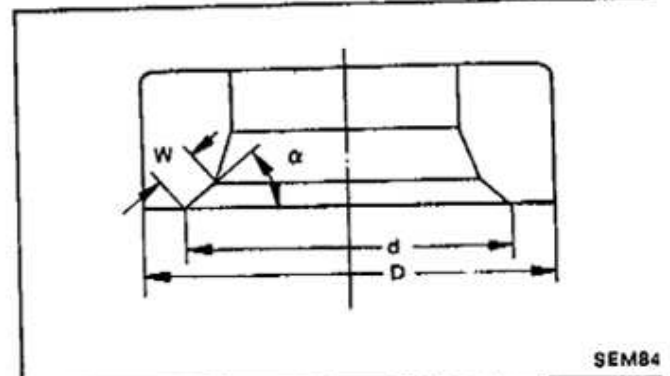

Contacting face angle "α"		45°
Contacting width "W"	Intake	1.63 (0.0642)
	Exhaust	1.55 (0.0610)
Finished diameter "d"	Intake	33.9 - 34.1 (1.335 - 1.343)
	Exhaust	29.4 - 29.6 (1.157 - 1.165)
Outer diameter "D"	Intake	36.780 - 36.796 (1.4480 - 1.4487)
	Exhaust	33.080 - 33.096 (1.3024 - 1.3030)
Cylinder head seat	Intake	36.700 - 36.716 (1.4449 - 1.4455)
	Exhaust	33.000 - 33.016 (1.2992 - 1.2998)
recess diameter		
Interference fit of seat insert		0.064 - 0.096 (0.0025 - 0.0038)

SERVICE DATA AND SPECIFICATIONS

GENERAL SPECIFICATIONS

Destination	Except for Europe & Hong Kong	For Europe & Hong Kong
Cylinder arrangement	4, in-line	
Displacement cm ³ (cu in)	1,990 (121.43)	1,991 (121.49)
Bore and stroke mm (in)	89 x 80 (3.50 x 3.15)	
Valve arrangement	D.O.H.C.	
Firing order	1-3-4-2	
Number of piston rings		
Compression	2	
Oil	1	
Number of main bearings	5	
Compression ratio	9.1	9.5

INSPECTION AND ADJUSTMENT CYLINDER HEAD

Unit: mm (in)

	Standard	Limit
Head surface flatness	Less than 0.05 (0.0020)	0.1 (0.004)

VALVE

Unit: mm (in)

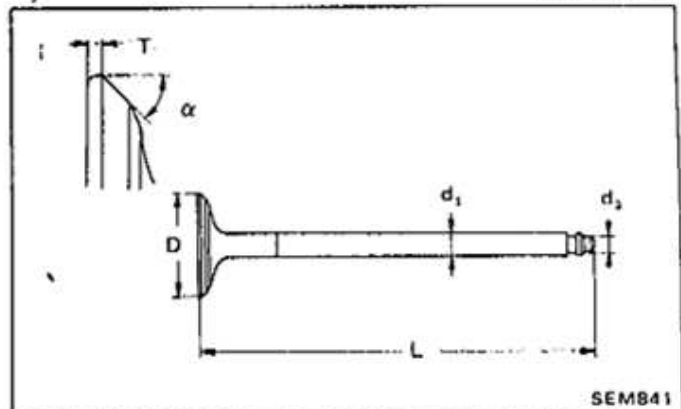

Valve head diameter "D"	Intake	34.5 (1.358)
	Exhaust	30.0 (1.181)
Valve length "L"	Intake	125.01 - 125.51 (4.922 - 4.941)
	Exhaust	124.96 - 125.46 (4.920 - 4.939)
Valve stem diameter "d ₁ "	Intake	6.960 - 6.975 (0.2740 - 0.2746)
	Exhaust	6.938 - 6.960 (0.2731 - 0.2740)
Valve stem end diameter "d ₂ "	Intake & Exhaust	5.572 - 5.590 (0.2194 - 0.2201)
Valve seat angle "α"		45° 15' - 45° 45'
Valve clearance (Hot)	Intake	0.30 (0.012)
	Exhaust	0.35 (0.014)
Valve clearance (Cold)*	Intake	0.20 - 0.26 (0.008 - 0.010)
	Exhaust	0.28 - 0.34 (0.011 - 0.013)

*Cold: Used as approximate values during engine assembly, clearances should ultimately be adjusted to the above hot values; refer to section MA for procedure.

Valve lifter

Unit: mm (in)

	Standard	Limit
Valve lifter outer diameter	33.950 - 33.975 (1.3366 - 1.3376)	--
Cylinder head valve lifter guide hole inner diameter	34.000 - 34.025 (1.3386 - 1.3396)	--
Valve lifter guide hole clearance (Oil clearance)	0.025 - 0.075 (0.0010 - 0.0030)	--

ALIGN

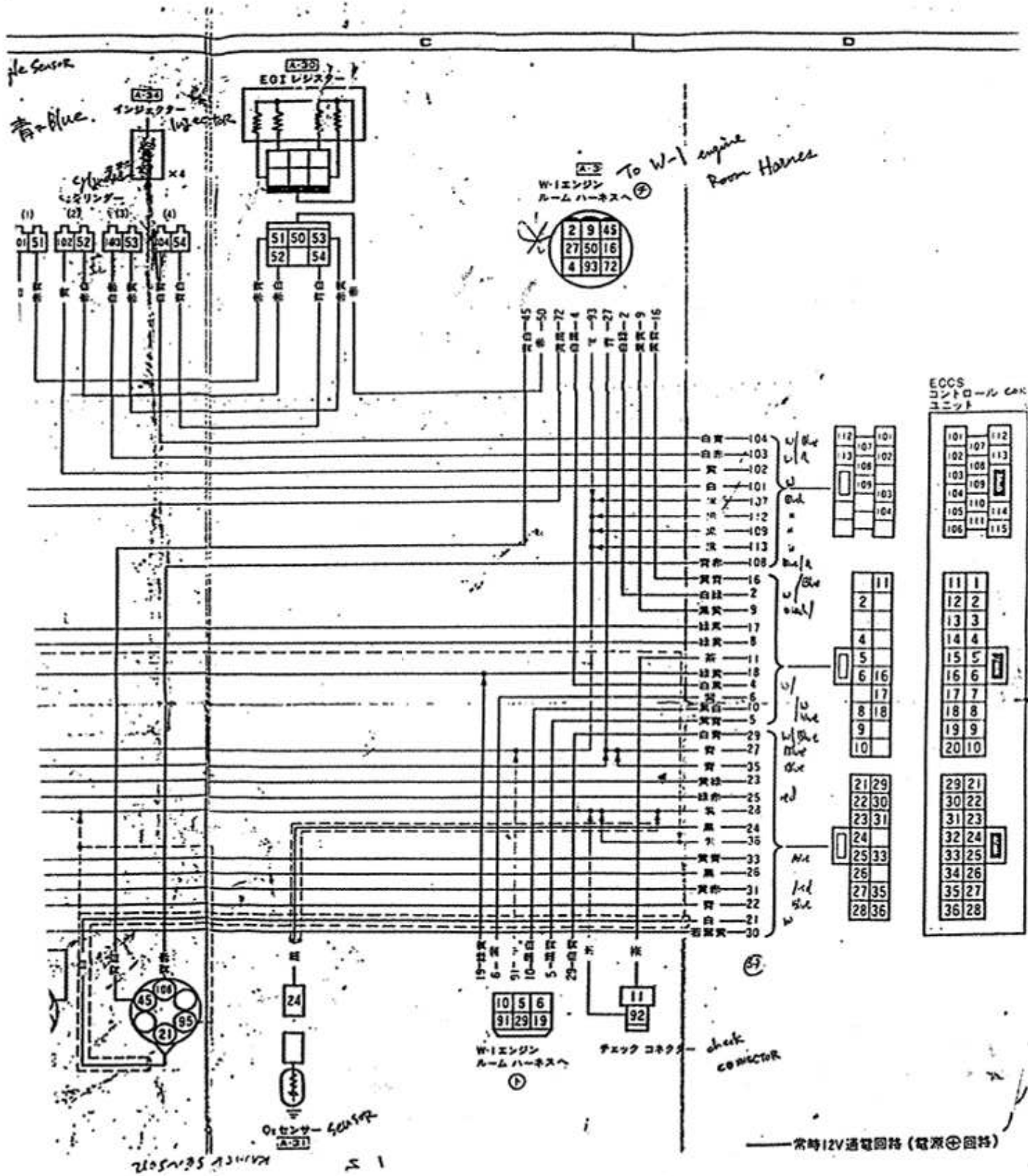

ALIGN

